

2V TUBULAR GEL SERIES VRLA BATTERY

CHISEN OPzV series high-performance energy storage batteries adopt tubular positive plates and the latest colloidal electrolyte technology. It has extremely high reliability and stability. Die-cast positive grid greatly improves corrosion resistance. The patented active material formula and fast PVC partitions ensure excellent performance. Products meet DIN standards, IEC standards and national standards. The OPzV series is designed to have a float charge life of more than 20 years, and the cycle performance is far superior to that of ordinary AGM products. It is ideal for float charging and cycling under extreme operating conditions. Such as outdoor telecommunications with unstable power, renewable energy storage systems and other harsh scenarios.

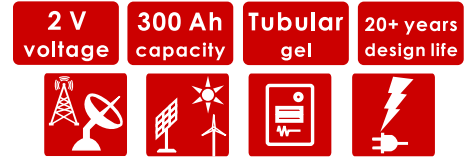

SPECIFICATIONS

Nominal Voltage (V)	2
Designed Floating Life (20°C)	20+ Years
Nominal Capacity (20°C)	300 Ah @ C10 (to 1.80Vpc)
Dimensions	L145mm × W206mm × H390mm
Approx. Weight	24.4 kg (53.8 lbs)
Terminal Type	Female Copper Insert M8 (torque:10~12N.m)
Internal Resistance	Approx. 0.8mOhm (fully charged @ 25°C)
Max. Charge Current	60 A
Max. Discharge Current (5S)	1500 A
Short Circuit Current	2600 A
Self Discharge	Approx. 2% per month @ 20°C
Ambient Temperature	Discharge: -40~65°C Charge: -30~65°C Storage: -25~45°C
Float Charge Voltage	2.23V @25°C (-3mV / °C/ cell)
Equalize Charge Voltage	2.35V @25°C
Container Material	ABS(UL94-V0 optional)



Complied standards

- IEC 60896-21/22
- DIN40472
- IEC61427
- YD/T1360
- Eurobat guide, long life
- BS6290 part 4
- UL1989

DIMENSIONS

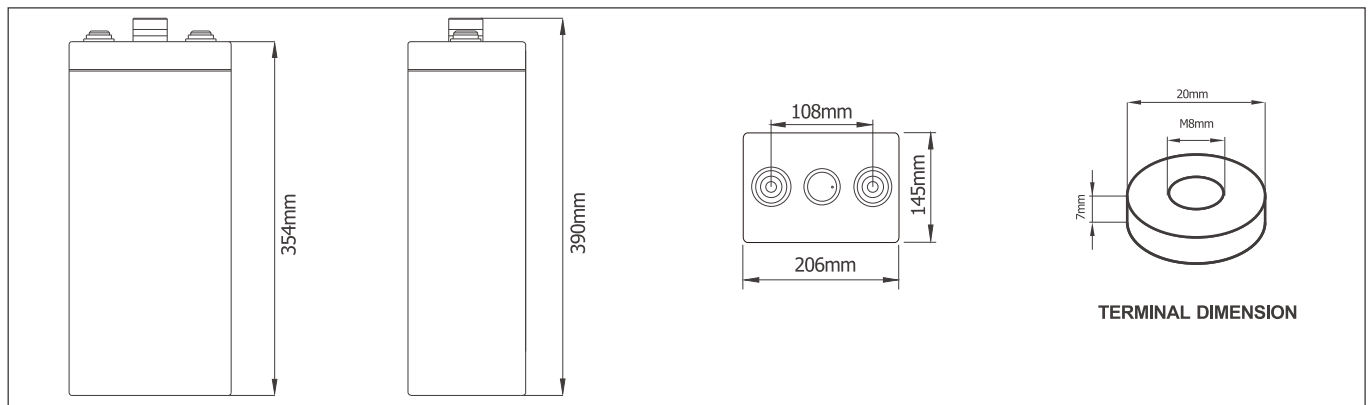

BATTERY DISCHARGE TABLE

Constant Current Discharge Characteristics: Amps (20°C)

F.V/Time	10min	15min	30min	1h	2h	3h	5h	8h	10h
1.90V	110	107	100	84.0	71.5	60.0	44.4	31.8	26.3
1.87V	150	140	124	98.0	80.0	66.1	48.2	33.8	27.8
1.85V	172	158	136	107	88.2	71.1	51.3	35.3	28.9
1.83V	201	176	147	118	94.2	75.1	52.5	36.4	29.4
1.80V	225	204	165	130	99.4	78.8	53.6	36.9	30.0
1.75V	238	224	193	142	104	81.0	54.6	37.5	30.9
1.70V	259	246	212	150	108	82.5	55.5	38.1	31.5
1.65V	303	277	231	159	111	84.0	56.7	38.7	32.1
1.60V	330	304	245	164	113	85.5	57.9	39.4	32.7

Constant Power Discharge Characteristics: W/cell (20°C)

F.V/Time	10min	15min	30min	1h	2h	3h	5h	8h	10h
1.90V	212	207	195	165	141	119	88.9	64.0	53.1
1.87V	284	266	238	189	156	130	95.7	67.4	55.6
1.85V	322	296	257	204	170	139	101	70.0	57.4
1.83V	371	326	275	223	180	145	102	71.5	57.9
1.80V	409	373	304	242	188	150	103	71.7	58.4
1.75V	427	403	351	260	193	152	104	72.0	59.5
1.70V	458	437	380	271	198	153	105	72.5	60.2
1.65V	526	484	408	285	201	154	106	72.8	60.7
1.60V	561	520	425	289	203	155	107	73.4	61.2

PARAMETERS FOR SOLAR & WIND APPLICATIONS

Long time discharge capacity for Solar & Wind applications

Capacity	C ₂₀ (Ah)	C ₂₄ (Ah)	C ₄₈ (Ah)	C ₇₂ (Ah)	C ₁₀₀ (Ah)	C ₁₂₀ (Ah)	C ₂₄₀ (Ah)
OPzV2-300	327	339	366	378	383	387	398
Final Voltage	1.80V						
	1.85V						

Solar & Wind applications parameters settings

Over voltage disconnect:	2.45±0.01V/cell @ 25°C
Regulation/equalize voltage:	2.40±0.01V/cell @ 25°C
Array reconnection voltage:	2.25±0.005V/cell @ 25°C
Float voltage setting:	2.27±0.005V/cell @ 25°C
Low voltage alarm voltage:	1.95±0.005V/cell @ 25°C
Low voltage disconnect:	1.90±0.005V/cell @ 25°C
Load reconnect voltage:	2.09±0.01V/cell @ 25°C
Temp. compensate coefficient:	-3~-5mV/cell/°C

CHARACTERISTICS

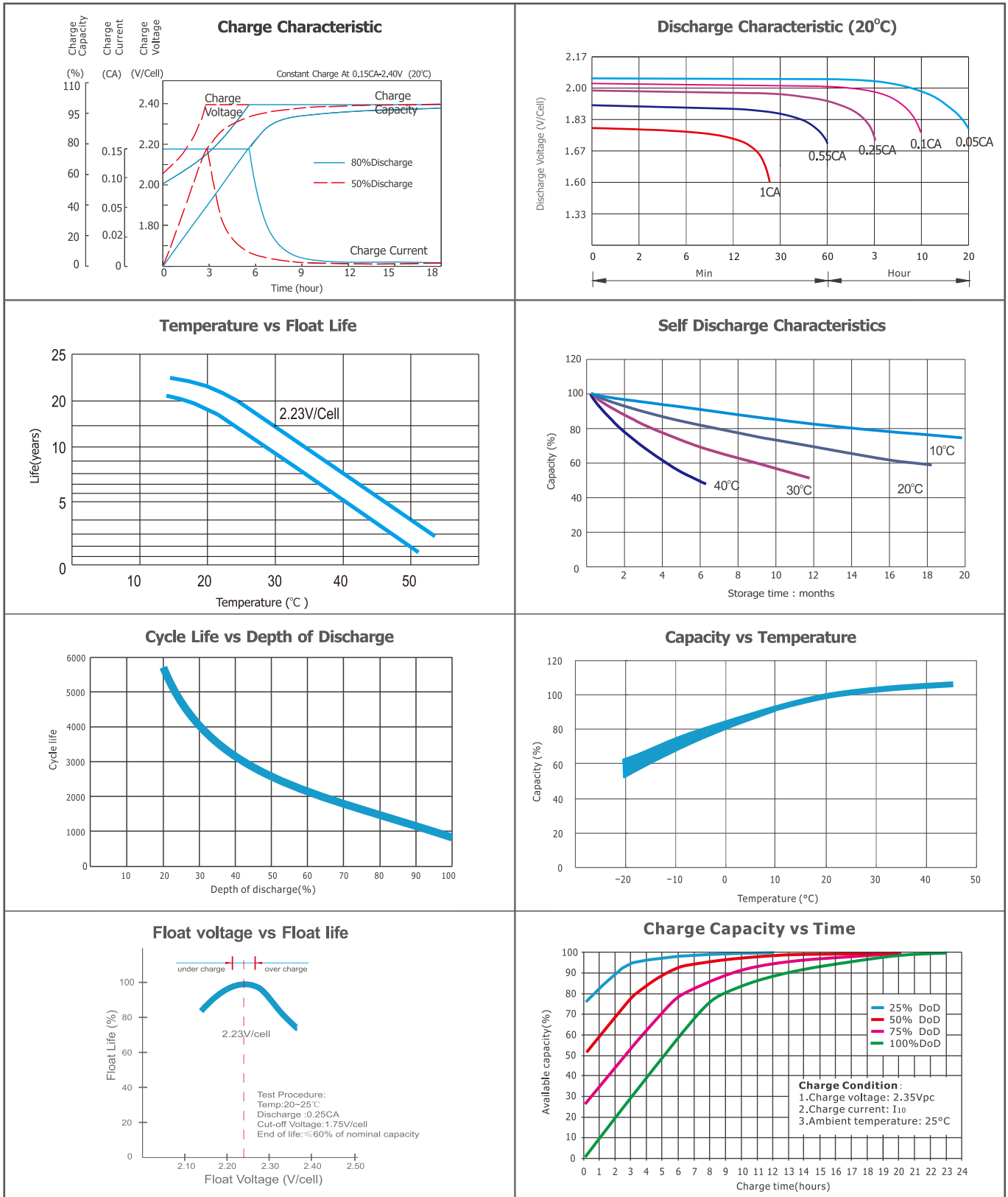

FINAL VOLTAGE SETTINGS RECOMMENDED ACCORDING TO THE DISCHARGE CURRENT

Discharge Current I (A)	$I < 0.05C$	$0.05C \leq I < 0.08C$	$0.08C \leq I < 0.2C$	$0.2C \leq I < 0.6C$	$0.6C \leq I < 1.0C$	$1C \leq I \leq 2C$
Final of Voltage	≥1.90Vpc	≥1.85Vpc	≥1.80 Vpc	≥1.75 Vpc	≥1.7 Vpc	≥1.6 Vpc

CONTACT US:

Company: Zhejiang Chisen Battery Co., Ltd
 Address: Room 3305, Building 2, Wealth Financial Center, Shangcheng District, Hangzhou, Zhejiang
 Website: <https://www.chisen.cn>
 Email: sales@chisen.cn chisenbattery@gmail.com
 Facebook: <https://www.facebook.com/chisenbattery>
 LinkedIn: <https://linkedin.com/company/chisen>
 VK: <https://vk.com/chisenbattery>

Note: All above information shall be changed without prior notice, CHISEN reserves the right to explain and update the latest information.