

## 2V TUBULAR GEL SERIES VRLA BATTERY

The OPzV series adopts an Immobilized Gel and Tubular Positive Plate technology. It offers high reliability and stable performance. By using die-casted positive grid and patented active material formula, it exceeds the DIN standard values and offer 20+ years design life in float service. It is very suitable for cyclic use under extreme operating conditions. This series is recommended for telecom outdoor applications, renewable energy systems and other harsh environment applications.

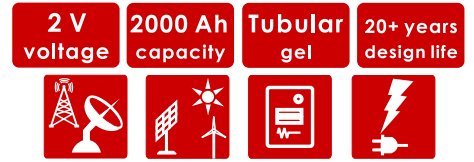

### SPECIFICATIONS

Nominal Voltage (V)	2
Designed Floating Life (20°C)	20+ Years
Nominal Capacity (20°C)	2000 Ah @ C <sub>10</sub> (to 1.80Vpc)
Dimensions	L399mm × W212mm × H807mm
Approx. Weight	145 kg (320 lbs)
Terminal Type	Female Copper Insert M8 (torque:10~12N.m)
Internal Resistance	Approx. 0.37mOhm (fully charged @ 25°C)
Max. Charge Current	400 A
Max. Discharge Current (5S)	3000 A
Short Circuit Current	8300 A
Self Discharge	Approx. 2% per month @ 20°C
Ambient Temperature	Discharge: -40~65°C Charge: -30~65°C Storage: -25~45°C
Float Charge Voltage	2.23V @25°C (-3mV / °C/ cell)
Equalize Charge Voltage	2.35V @25°C
Container Material	ABS(UL94-V0 optional)



### Complied standards

- IEC 60896-21/22
- DIN40472
- IEC61427
- YD/T1360
- Eurobat guide, long life
- BS6290 part 4
- UL1989

### DIMENSIONS

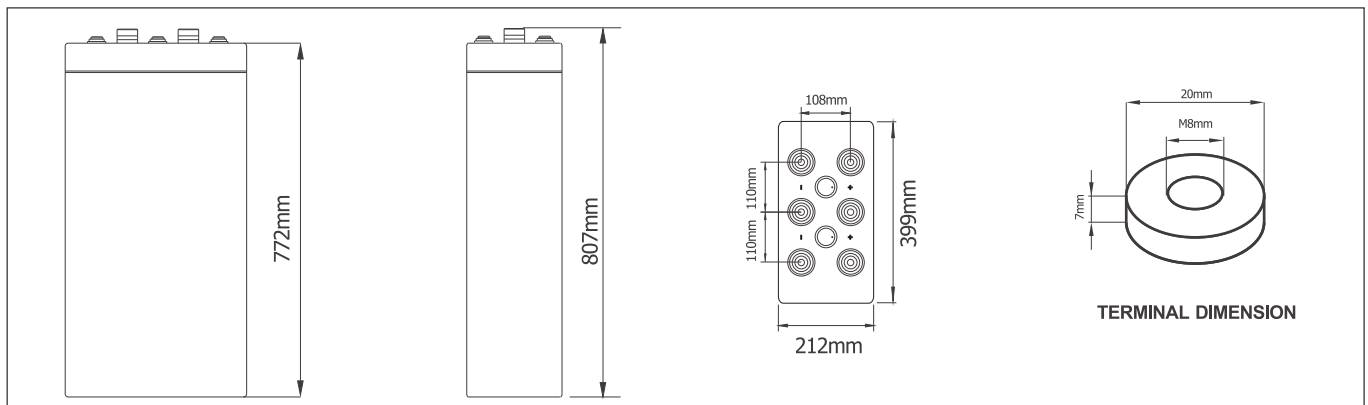

### BATTERY DISCHARGE TABLE

#### Constant Current Discharge Characteristics: Amps (20°C)

F.V/Time	10m in	15m in	30m in	1h	2h	3h	5h	8h	10h
1.90V	708	688	643	543	467	392	290	208	172
1.87V	965	901	798	634	523	432	315	221	181
1.85V	1110	1016	875	692	576	465	335	231	188
1.83V	1293	1132	946	763	616	491	343	238	192
1.80V	1447	1312	1058	841	649	515	350	241	200
1.75V	1534	1441	1242	915	678	529	357	245	202
1.70V	1669	1583	1364	967	704	539	363	249	206
1.65V	1949	1782	1486	1028	724	549	370	253	210
1.60V	2123	1956	1576	1061	739	559	378	258	214

#### Constant Power Discharge Characteristics: W/cell (20°C)

F.V/Time	10m in	15m in	30m in	1h	2h	3h	5h	8h	10h
1.90V	1367	1333	1253	1066	924	780	581	418	347
1.87V	1828	1713	1528	1224	1021	851	626	441	363
1.85V	2073	1907	1654	1321	1113	906	659	457	375
1.83V	2387	2099	1767	1440	1176	946	667	467	378
1.80V	2634	2400	1953	1568	1226	982	673	468	382
1.75V	2747	2594	2258	1683	1262	994	677	470	389
1.70V	2948	2810	2447	1755	1295	1001	681	473	393
1.65V	3382	3113	2625	1841	1316	1008	688	475	397
1.60V	3609	3348	2731	1867	1323	1011	694	479	400

### PARAMETERS FOR SOLAR & WIND APPLICATIONS

Long time discharge capacity for Solar & Wind applications

Capacity	C <sub>20</sub> (Ah)	C <sub>24</sub> (Ah)	C <sub>48</sub> (Ah)	C <sub>72</sub> (Ah)	C <sub>100</sub> (Ah)	C <sub>120</sub> (Ah)	C <sub>240</sub> (Ah)
OPzV2-2000	2150	2185	2440	2500	2535	2545	2580
Final Voltage	1.85V						

#### Solar & Wind applications parameters settings

Over voltage disconnect:	2.45±0.01V/cell @ 25°C
Regulation/equalize voltage:	2.40±0.01V/cell @ 25°C
Array reconnection voltage:	2.25±0.005V/cell @ 25°C
Float voltage setting:	2.27±0.005V/cell @ 25°C
Low voltage alarm voltage:	1.95±0.005V/cell @ 25°C
Low voltage disconnect:	1.90±0.005V/cell @ 25°C
Load reconnect voltage:	2.09±0.01V/cell @ 25°C
Temp. compensate coefficient:	-3~-5mV/cell/°C

## CHARACTERISTICS

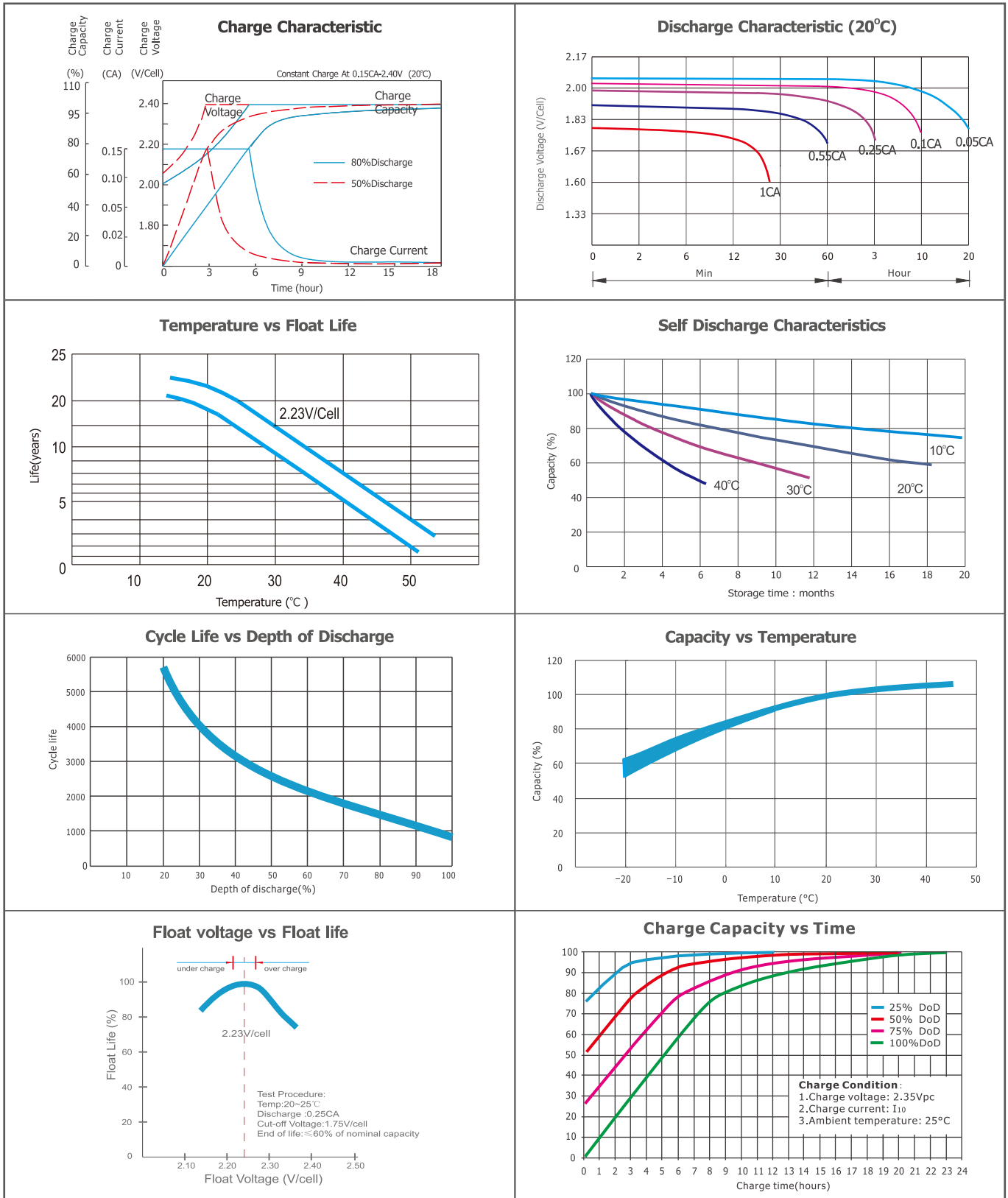

### FINAL VOLTAGE SETTINGS RECOMMENDED ACCORDING TO THE DISCHARGE CURRENT

Discharge Current I (A)	I < 0.05C	0.05C ≤ I < 0.08C	0.08C ≤ I < 0.2C	0.2C ≤ I < 0.6C	0.6C ≤ I < 1.0C	1C ≤ I ≤ 2C
Final of Voltage	≥1.90Vpc	≥1.85Vpc	≥1.80 Vpc	≥1.75 Vpc	≥1.7 Vpc	≥1.6 Vpc

### CONTACT US:

Company: Zhejiang Chisen Battery Co., Ltd  
 Address: Room 3305, Building 2, Wealth Financial Center, Shangcheng District, Hangzhou, Zhejiang  
 Website: <https://www.chisen.cn>  
 Email: [sales@chisen.cn](mailto:sales@chisen.cn) [chisenbattery@gmail.com](mailto:chisenbattery@gmail.com)  
 Facebook: <https://www.facebook.com/chisenbattery>  
 LinkedIn: <https://linkedin.com/company/chisen>  
 VK: <https://vk.com/chisenbattery>

Note: All above information shall be changed without prior notice, CHISEN reserves the right to explain and update the latest information.