

## 2V TUBULAR GEL SERIES VRLA BATTERY

The OPzV series adopts an Immobilized Gel and Tubular Positive Plate technology. It offers high reliability and stable performance. By using die-casted positive grid and patented active material formula, it exceeds the DIN standard values and offer 20+ years design life in float service. It is very suitable for cyclic use under extreme operating conditions. This series is recommended for telecom outdoor applications, renewable energy systems and other harsh environment applications.

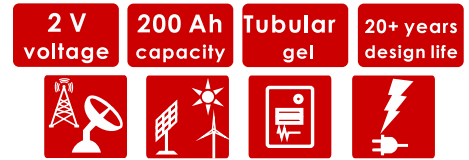

### SPECIFICATIONS

Nominal Voltage (V)	2
Designed Floating Life (20°C)	20+ Years
Nominal Capacity (20°C)	200 Ah @ C10 (to 1.80Vpc)
Dimensions	L103mm × W206mm × H390mm
Approx. Weight	17.0 kg (37.5 lbs)
Terminal Type	Female Copper Insert M8 (torque:10~12N.m)
Internal Resistance	Approx. 1.0mOhm (fully charged @ 25°C)
Max. Charge Current	40 A
Max. Discharge Current (5S)	1000 A
Short Circuit Current	1800 A
Self Discharge	Approx. 2% per month @ 20°C
Ambient Temperature	Discharge: -40~65°C Charge: -30~65°C Storage: -25~45°C
Float Charge Voltage	2.23V @25°C (-3mV / °C/ cell)
Equalize Charge Voltage	2.35V @25°C
Container Material	ABS(UL94-V0 optional)



### Complied standards

- IEC 60896-21/22
- DIN40472
- IEC61427
- YD/T1360
- Eurobat guide, long life
- BS6290 part 4
- UL1989

### DIMENSIONS

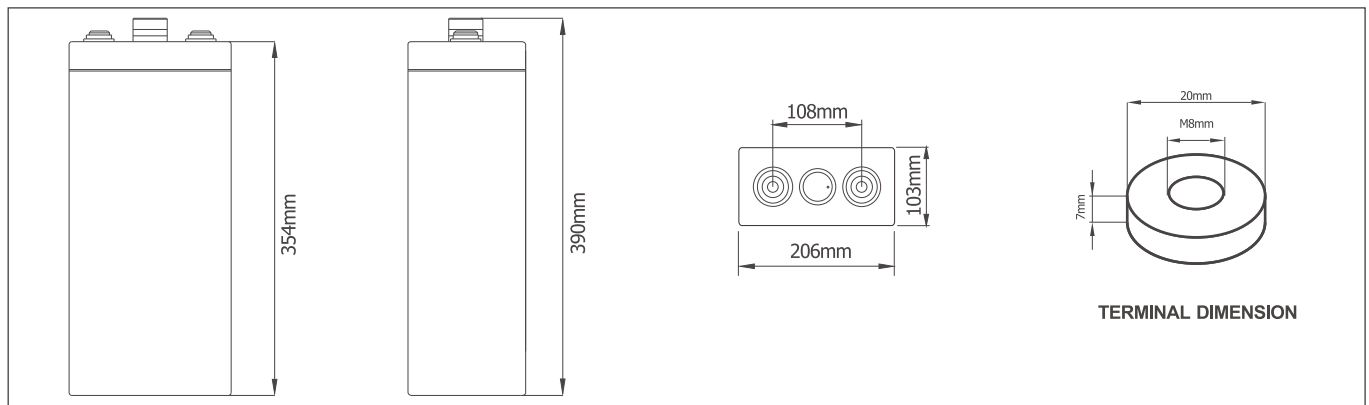

### BATTERY DISCHARGE TABLE

#### Constant Current Discharge Characteristics: Amps (20°C)

F.V/Tim e	10m in	15m in	30m in	1h	2h	3h	5h	8h	10h
1.90V	73.4	71.3	66.7	56.0	47.7	40.0	29.6	21.2	17.5
1.87V	100	93.3	82.7	65.3	53.3	44.1	32.1	22.5	18.5
1.85V	115	105	90.7	71.3	58.8	47.4	34.2	23.5	19.2
1.83V	134	117	98.0	78.7	62.8	50.1	35.0	24.3	19.6
1.80V	150	136	110	86.7	66.2	52.5	35.7	24.6	20.0
1.75V	159	149	129	94.3	69.2	54.0	36.4	25.0	20.6
1.70V	173	164	141	100	71.8	55.0	37.0	25.4	21.0
1.65V	202	185	154	106	73.9	56.0	37.8	25.8	21.4
1.60V	220	203	163	109	75.4	57.0	38.6	26.3	21.8

#### Constant Power Discharge Characteristics: W/cell (20°C)

F.V/Tim e	10m in	15m in	30m in	1h	2h	3h	5h	8h	10h
1.90V	142	138	130	110	94.2	79.6	59.3	42.6	35.4
1.87V	189	178	158	126	104	86.8	63.8	45.0	37.1
1.85V	215	198	171	136	114	92.4	67.3	46.7	38.2
1.83V	247	218	183	148	120	96.6	68.0	47.7	38.6
1.80V	273	249	202	162	125	100	68.7	47.8	39.0
1.75V	285	269	234	173	129	101	69.1	48.0	39.7
1.70V	306	291	254	181	132	102	69.5	48.3	40.1
1.65V	350	323	272	190	134	103	70.2	48.5	40.5
1.60V	374	347	283	192	135	103	70.8	48.9	40.8

### PARAMETERS FOR SOLAR & WIND APPLICATIONS

Long time discharge capacity for Solar & Wind applications

Capacity	C20 (Ah)	C24 (Ah)	C48 (Ah)	C72 (Ah)	C100 (Ah)	C120 (Ah)	C240 (Ah)
OPzV2-200	220	226	244	252	255	258	265
Final Voltage	1.80V						
	1.85V						

### Solar & Wind applications parameters settings

Over voltage disconnect:	2.45±0.01V/cell @ 25°C
Regulation/equalize voltage:	2.40±0.01V/cell @ 25°C
Array reconnection voltage:	2.25±0.005V/cell @ 25°C
Float voltage setting:	2.27±0.005V/cell @ 25°C
Low voltage alarm voltage:	1.95±0.005V/cell @ 25°C
Low voltage disconnect:	1.90±0.005V/cell @ 25°C
Load reconnect voltage:	2.09±0.01V/cell @ 25°C
Temp. compensate coefficient:	-3~-5mV/cell/°C