

2V TUBULAR GEL SERIES VRLA BATTERY

The OPzV series adopts an Immobilized Gel and Tubular Positive Plate technology. It offers high reliability and stable performance. By using die-casted positive grid and patented active material formula, it exceeds the DIN standard values and offer 20+ years design life in float service. It is very suitable for cyclic use under extreme operating conditions. This series is recommended for telecom outdoor applications, renewable energy systems and other harsh environment applications.

2 V voltage	1500 Ah capacity	Tubular gel	20+ years design life



SPECIFICATIONS

Nominal Voltage (V)	2
Designed Floating Life (20°C)	20+ Years
Nominal Capacity (20°C)	1500 Ah @ C ₁₀ (to 1.80Vpc)
Dimensions	L275mm × W210mm × H831mm
Approx. Weight	102 kg (225 lbs)
Terminal Type	Female Copper Insert M8 (torque:10~12N.m)
Internal Resistance	Approx. 0.45mOhm (fully charged @ 25°C)
Max. Charge Current	300 A
Max. Discharge Current (5S)	3000 A
Short Circuit Current	6200 A
Self Discharge	Approx. 2% per month @ 20°C
Ambient Temperature	Discharge: -40~65°C Charge: -30~65°C Storage: -25~45°C
Float Charge Voltage	2.23V @25°C (-3mV / °C/ cell)
Equalize Charge Voltage	2.35V @25°C
Container Material	ABS(UL94-V0 optional)



Complied standards

- IEC 60896-21/22
- DIN40472
- IEC61427
- YD/T1360
- Eurobat guide, long life
- BS6290 part 4
- UL1989

DIMENSIONS

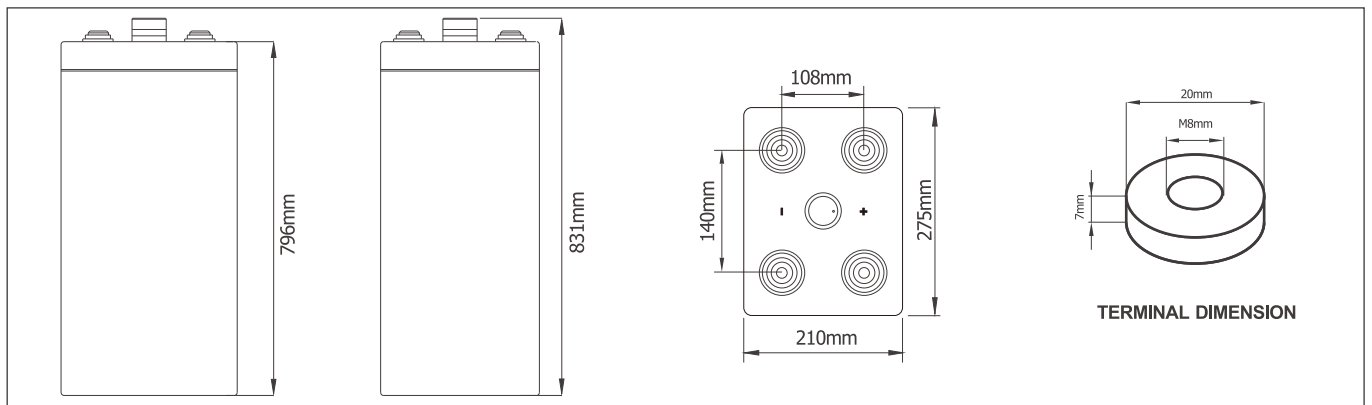

BATTERY DISCHARGE TABLE

Constant Current Discharge Characteristics: Amps (20°C)

F.V/Time	10m in	15m in	30m in	1h	2h	3h	5h	8h	10h
1.90V	534	519	485	407	350	294	218	156	129
1.87V	727	679	601	475	392	324	236	165	136
1.85V	837	766	660	519	432	349	251	173	141
1.83V	975	854	713	572	462	368	257	179	144
1.80V	1091	989	798	631	487	386	262	181	150
1.75V	1157	1086	936	686	508	397	268	184	151
1.70V	1259	1193	1028	725	528	404	272	187	154
1.65V	1470	1343	1120	771	543	412	278	190	157
1.60V	1600	1474	1188	795	554	419	284	193	160

Constant Power Discharge Characteristics: W/cell (20°C)

F.V/Time	10m in	15m in	30m in	1h	2h	3h	5h	8h	10h
1.90V	1031	1005	944	799	693	585	436	313	260
1.87V	1378	1291	1152	918	766	638	469	330	272
1.85V	1563	1438	1247	991	834	679	494	343	281
1.83V	1800	1583	1332	1080	882	710	500	350	284
1.80V	1985	1809	1472	1176	919	736	505	351	286
1.75V	2071	1956	1702	1262	947	745	508	353	292
1.70V	2223	2118	1845	1316	971	751	511	355	295
1.65V	2549	2347	1979	1381	987	756	516	357	297
1.60V	2721	2524	2059	1400	993	758	521	359	300

PARAMETERS FOR SOLAR & WIND APPLICATIONS

Long time discharge capacity for Solar & Wind applications

Capacity	C ₂₀ (Ah)	C ₂₄ (Ah)	C ₄₈ (Ah)	C ₇₂ (Ah)	C ₁₀₀ (Ah)	C ₁₂₀ (Ah)	C ₂₄₀ (Ah)
OPzV2-1500	1610	1640	1830	1860	1900	1910	1940
Final Voltage	1.85V						

Solar & Wind applications parameters settings

Over voltage disconnect:	2.45±0.01V/cell @ 25°C
Regulation/equalize voltage:	2.40±0.01V/cell @ 25°C
Array reconnection voltage:	2.25±0.005V/cell @ 25°C
Float voltage setting:	2.27±0.005V/cell @ 25°C
Low voltage alarm voltage:	1.95±0.005V/cell @ 25°C
Low voltage disconnect:	1.90±0.005V/cell @ 25°C
Load reconnect voltage:	2.09±0.01V/cell @ 25°C
Temp. compensate coefficient:	-3~-5mV/cell/°C

CHARACTERISTICS

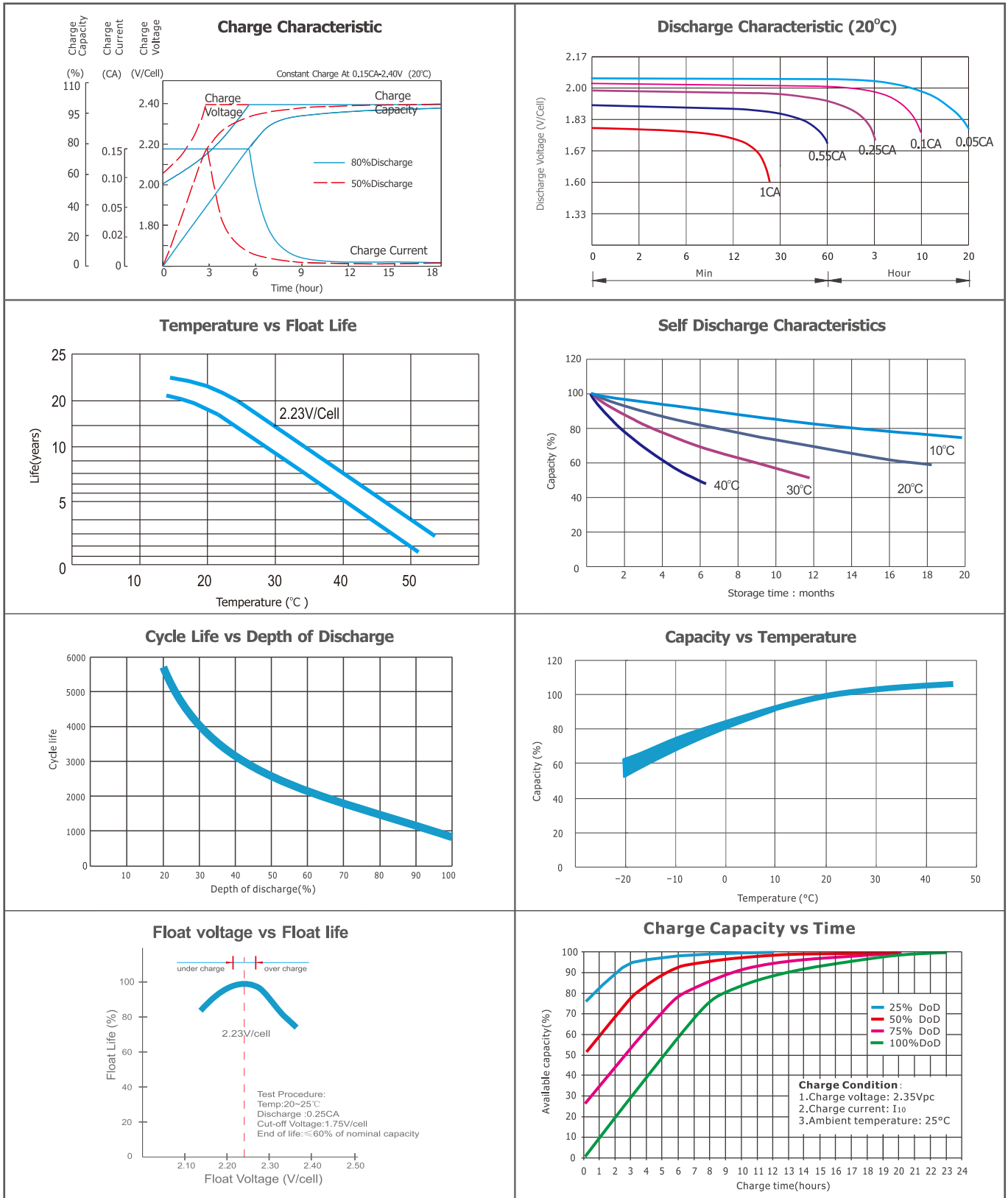

FINAL VOLTAGE SETTINGS RECOMMENDED ACCORDING TO THE DISCHARGE CURRENT

Discharge Current I (A)	I < 0.05C	0.05C ≤ I < 0.08C	0.08C ≤ I < 0.2C	0.2C ≤ I < 0.6C	0.6C ≤ I < 1.0C	1C ≤ I ≤ 2C
Final of Voltage	≥1.90Vpc	≥1.85Vpc	≥1.80 Vpc	≥1.75 Vpc	≥1.7 Vpc	≥1.6 Vpc

CONTACT US:

Company: Zhejiang Chisen Battery Co., Ltd
 Address: Room 3305, Building 2, Wealth Financial Center, Shangcheng District, Hangzhou, Zhejiang
 Website: <https://www.chisen.cn>
 Email: sales@chisen.cn chisenbattery@gmail.com
 Facebook: <https://www.facebook.com/chisenbattery>
 LinkedIn: <https://linkedin.com/company/chisen>
 VK: <https://vk.com/chisenbattery>
 Note: All above information shall be changed without prior notice, CHISEN reserves the right to explain and update the latest information.